



SPOT 1200

PLAY TEST

GOLDEN



## Lens and electronic focusing

The optical unit uses a wide-angle 24° lens with electronic focusing, which ensures a perfectly clear-cut image, whatever the distance or beam angle.

An additional lens housed inside the projector can be fitted by hand to reduce the light beam to 16°.

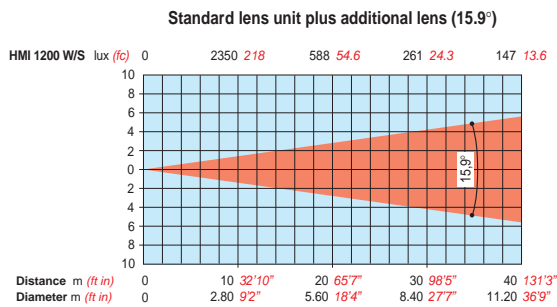
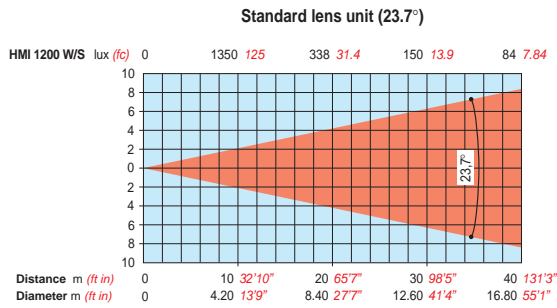
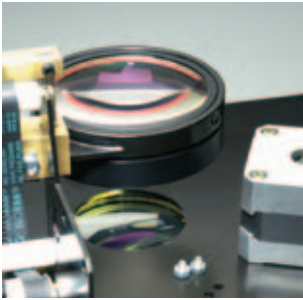

## Frost and prism

The Frost effect goes from a "spotlight" effect to a "diffused wash" effect. The projector also comes with a 5 facet prism that multiplies any projected image.



5 facet prism

## High quality graphics

Golden Spot 1200 comes with two separate gobo wheels that can be used in combination: one for bi-directional rotating gobos with adjustable speed, indexable over 540° with selectable 16 bit resolution, and the other for fixed gobos.

The gobos can be interchanged and selected from a vast range of dichroic and photographic versions, in decorative glass or metal.

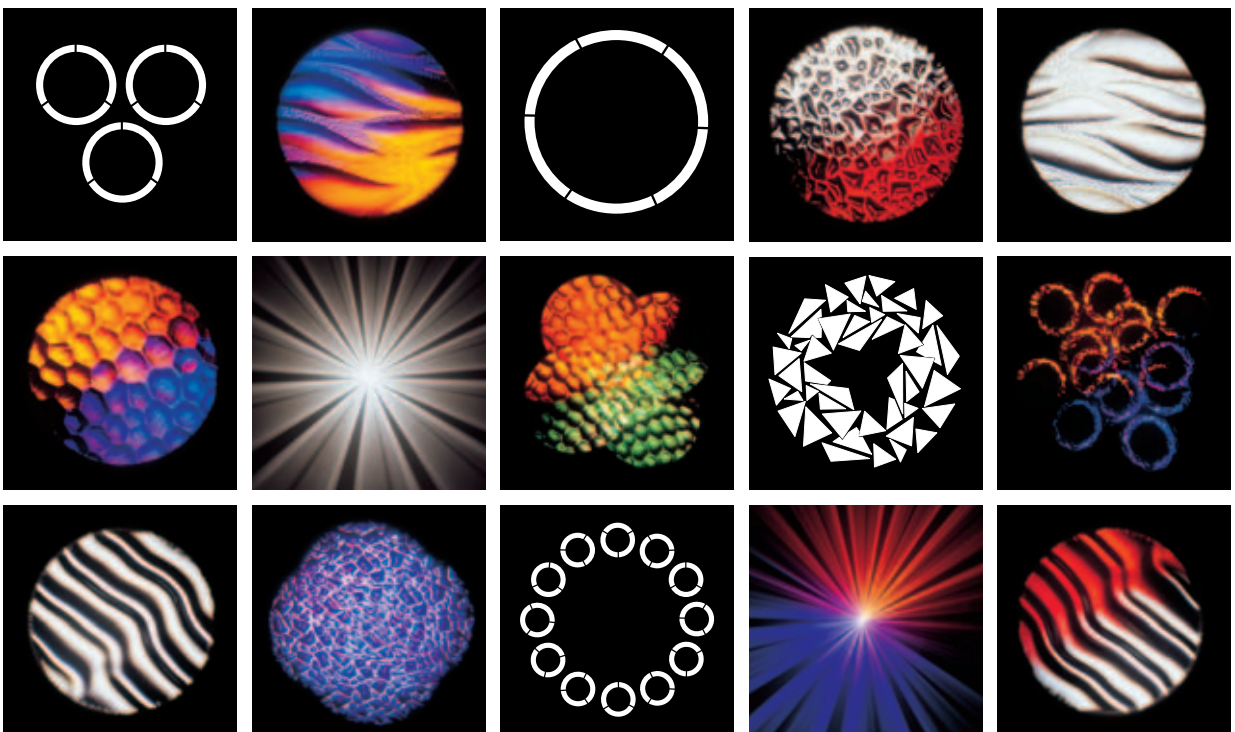

**Standard lens unit with frost (43.1° 10% - 22.4° 50%)**

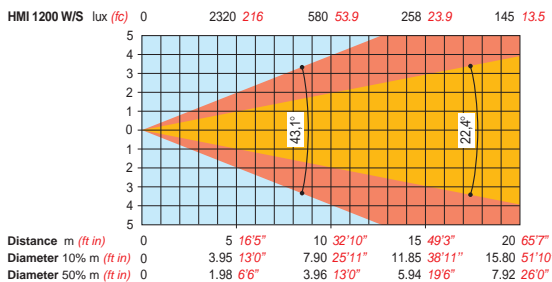

**Standard lens unit plus additional lens with frost (37.6° 10% - 17.5° 50%)**

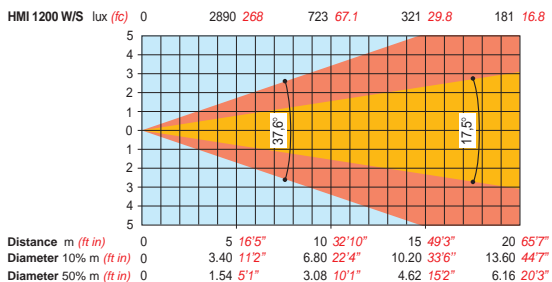

Key. Diameter 10% - 50%: beam diameter for 10% and 50% of maximum illumination.

**Other effects**

One of the many effects of Golden Spot 1200 is a high speed iris diaphragm that opens and closes the beam angle at the desired speed.

It also comes with a mechanical dimmer ranging from 0 to 100% with even changes from one level to another, instant beam stop and strobe effect with adjustable frequency from 1 to 11 flashes per second.

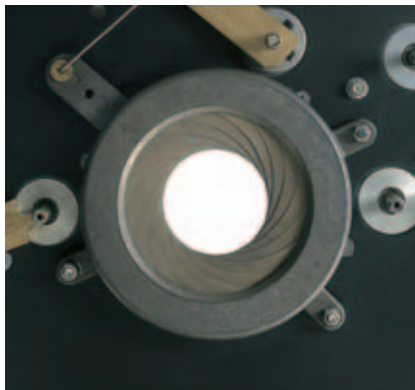

High speed Iris



Dimmer and Stop/Strobe blades

**Colors and special effects**

The 10 selected dichroic filters fitted on two wheels generate a wide range of colors and can be used in combination.

The special effects include two filters for correcting the color temperature to 3,200 K (hot filter) and to 6,000 K (cold filter).



Color Effects discs

**Channels**

CHANNELS													
%	1	2	3	4	5	6	7	8	9	10	11	12	13
	IRIS	Color disc 1	Color disc 2 prism and frost	Dimmer stopper strobe	PAN	TILT	Rotating gobo change	Gobo rotation	Fixed gobo change	Focus	PAN fine	TILT fine	Gobo fine
100%													
75%													
50%													
25%													
0%													

**Golden Spot 1200**

is an innovative effects projector, more powerful than the current industry standard, that combines high performance with a low budget.

It is therefore ideal for every professional lighting application, from touring and theatres to television and discotheques, especially whenever you want to keep investment and maintenance costs low.

**Golden Spot 1200**

# Golden Color 1200

Golden Color 1200

is a moving body

washlight that

combines power

and economy.

Equipped with a

state-of-the-art

CMY system +

Amber filter, it

provides linear

correction of the

colour temperature

as well as an

unbeatably broad

and uniform

diffusion of light.

It is ideal for

touring, TV, theatres,

discotheques and

wherever power

is the priority but at

a low cost.

## CMY + Amber color system

Golden Color 1200 adopts the CMY system + Amber, which produces infinite color tones and can fade from one tone to another at adjustable speed.

The Amber filter, also with gradual insertion, creates "pastel" shades much sought-after among Lighting Designers.

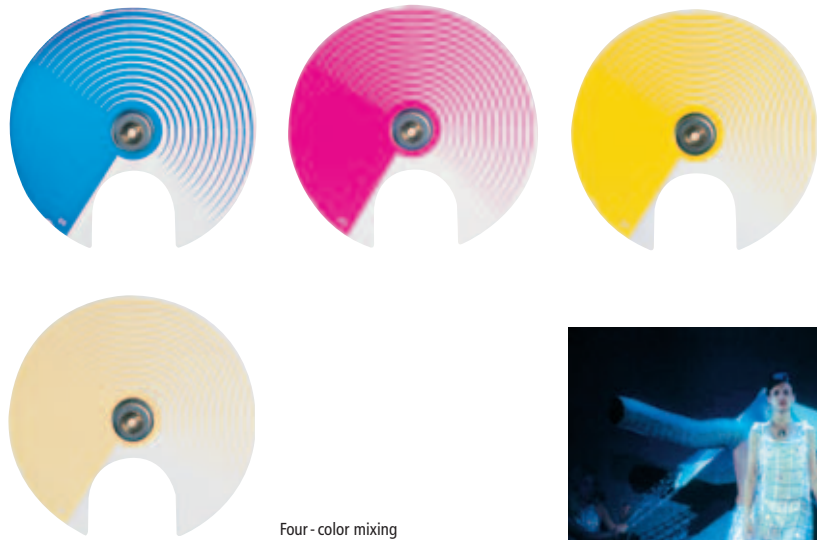

Four - color mixing

## Linear correction of the color temperature

When using a combination of several projectors in professional environments (i.e. when using several projectors in sequence during the same scene), linear correction of the color temperature is crucial in order to maintain color uniformity.

Golden Color 1200 uses the GTC system, designed and developed by Clay Paky, which gradually corrects the color temperature from 6,000 K to 3,200 K.

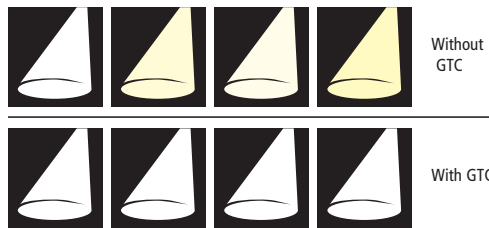

## Dimmer-Stop-Strobe

The dimmer effect allows you to vary luminous intensity from 0 to 100%, with an even change from one lighting level to another. Golden Color 1200 also offers an instant beam stop and a strobe effect at adjustable frequency, from 1 to 7 flashes per second.



## Frost and ovalised projection

Golden Color 1200 boasts Clay Paky's exclusive and patented Frost filter. It comes with a spherical cap in high quality optical glass, which evenly diffuses the light and optimises luminous efficiency, maintaining the brilliance of the beam. The projector also has filters for ovalised projection.

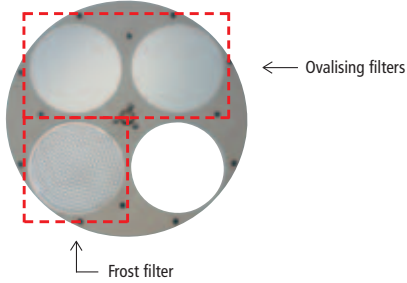

### Standard lens only (12.7° 10% - 7° 50%)

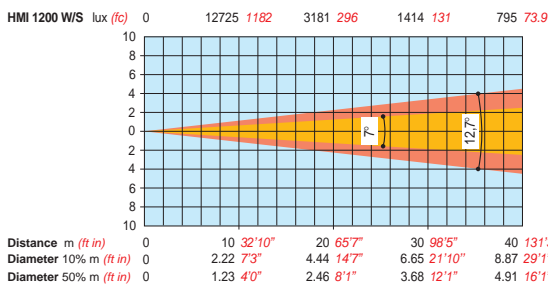

### Standard lens plus frost filter (30.0° 10% - 18.9° 50%)

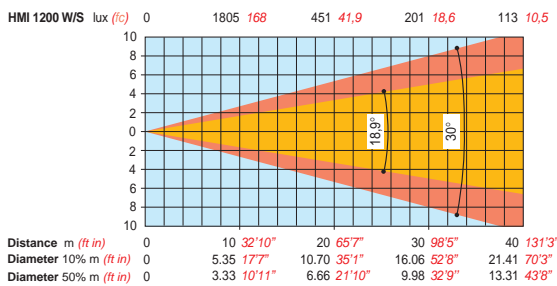

### With Color CYC (79.2° 10% - 45.2° 50%)

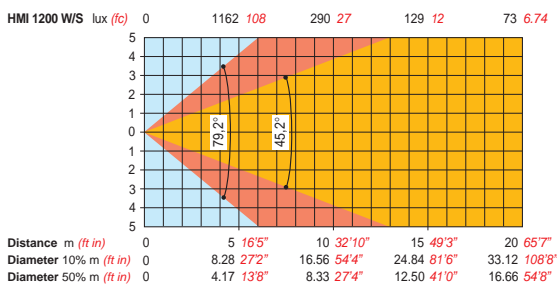

### With Color CYC plus frost filter (83.7° 10% - 50.4° 50%)

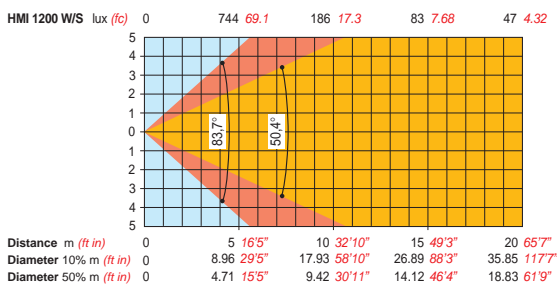

Key. Diameter 10% - 50%: beam diameter for 10% and 50% of maximum illumination.

## Color CYC

Color CYC is an accessory consisting of a high quality microlens filter that guarantees a totally uniform diffusion of light up to an 80° beam angle!



Golden Color 1200 is best used with Color CYC in professional applications like television studios, theatres, exhibitions, architectural settings and wherever uniformity of color is a must, even at very close projection range.

To use Color CYC on Golden Color 1200, just remove the front cap of the washlight and replace it with the Color CYC cap.

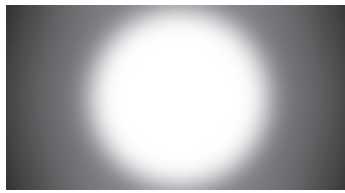

Without Color CYC



With Color CYC

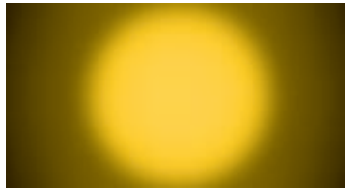

Without Color CYC



With Color CYC



Without Color CYC



With Color CYC

## Channels

CHANNELS										
%	1	2	3	4	5	6	7	8	9	10
	Color mixing			Dimmer Sopper Strobe	PAN	TILT	Amber Filter	Frost ovalising	PAN fine	TILT fine
100%										
75%										
50%										
25%										
0%										



Features common to the two luminaires



### High performance lamp

The two "Golden" projectors owe their high standards also to the powerful HMI 1200 W/S Osram discharge lamp. This lamp, specially developed for professional projectors, guarantees reliability, luminous efficiency, constant color temperature and very small dimensions.



### Smooth, flawless movements

The 8 or 16-bit resolution of the microsteps, selected by a special switch, make the movements (Pan 450° and Tilt 252°) extremely smooth and extensive.

### Return to starting position

Clay Paky has included encoder repositioning in these models to avoid wasting time realigning the projector after accidental movements.

The encoders register unwanted Pan and Tilt movement and return the projector to the programmed position.

### Moving body lock

To facilitate handling and transport, Clay Paky has been the first to design a system that locks both the Pan and Tilt mechanisms, keeping the projector head steady.



### Easy access to inside the projector

The "shell" shaped body of the projector allows easy and immediate access to the inside, making checking, cleaning and maintenance work easier for the operators.



### Plate for quick attachment

For quick and accurate mounting of the projectors on their support structures, Clay Paky has provided an integral base plate and two Omega brackets designed for standard attachment systems.



# Technical data for Golden Spot 1200 and Golden Color 1200

<b>Power supplies</b>	• 230 V 50 Hz • 240 V 50 Hz • 208 V 60 Hz • 200 V 50 Hz • 200 V 60 Hz
<b>Input power</b>	• 1700 VA at 230 V 50 HZ (p.f. correction 140 µF standard)
<b>Lamp</b>	<ul style="list-style-type: none"> <li>• Metal iodide lamp with built-in power supply unit.</li> <li>• Type HMI 1200W/S</li> <li>• Connection SFC 10-4</li> <li>• Color temperature 6,000 K</li> <li>• Luminous flux 110,000 lm</li> <li>• Average life 750 h</li> <li>• Any working position</li> </ul>
<b>Motors</b>	<p><b>Golden Spot 1200:</b> 11 stepper motors, operating with microsteps, totally controlled by a microprocessor.</p> <p><b>Golden Color 1200:</b> 9 stepper motors, operating with microsteps, totally controlled by a microprocessor.</p>
<b>Optical unit</b>	<p><b>Golden Spot 1200:</b></p> <ul style="list-style-type: none"> <li>• Twin lens condenser.</li> <li>• Spherical reflector with high luminous efficiency.</li> </ul> <p><b>Golden Color 1200:</b></p> <ul style="list-style-type: none"> <li>• Fresnel Lens: diameter 200 mm, focal length 140 mm.</li> <li>• Elliptic reflector with high luminous efficiency.</li> </ul>
<b>Channels</b>	<p><b>Golden Spot 1200:</b> • 10, 12 or 13 control channels.</p> <p><b>Golden Color 1200:</b> • 8 or 10 control channels.</p>
<b>Inputs</b>	• DMX 512 • RS 232/423
<b>Moving body</b>	<ul style="list-style-type: none"> <li>• Movement powered by two stepper motors, controlled by a microprocessor.</li> <li>• Automatic repositioning of PAN and TILT after accidental movements not controlled by control unit.</li> <li>• Angle: - PAN = 450° - TILT = 252°</li> <li>• Maximum speeds: - PAN = 4.0 sec (360°) - TILT = 3.2 sec (252°)</li> <li>• Resolution: - PAN = 1.76° - PAN FINE = 0.007° - TILT = 0.98° - TILT FINE = 0.004°</li> </ul>
<b>Protection rating</b>	• IP 20
<b>CE Marking</b>	• In conformity with the European Union Low Voltage Directive 73/23 and Electromagnetic Compatibility Directive 89/336.
<b>Safety devices</b>	<ul style="list-style-type: none"> <li>• Bipolar circuit breaker with thermal protection.</li> <li>• Automatic break of power supply in case of overheating or failed operation of cooling system.</li> <li>• Automatic power supply cut off when the lamp covers are opened.</li> <li>• Four fixing points for safety cable.</li> </ul>
<b>Cooling</b>	• Forced ventilation with axial fans.
<b>Body</b>	<ul style="list-style-type: none"> <li>• In die-cast aluminium and steel.</li> <li>• Epoxy powder painting.</li> <li>• Two side handles for transportation.</li> <li>• Device locking PAN and TILT mechanisms for transportation and maintenance.</li> </ul>
<b>Working position</b>	• Functioning in any position.
<b>Weights and dimensions</b>	• Weight: approx 55 kg. • Dimensions: see drawing (mm/inches).

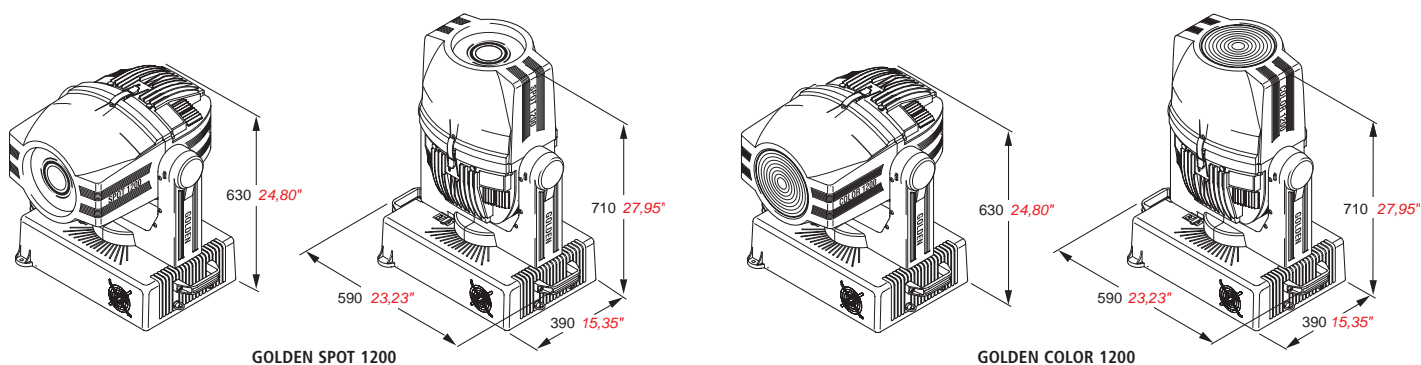

## Sales Codes

C61030	Golden Spot 1200
C61035	Golden Color 1200

## Accessories

L10055	Osram HMI 1200 W/S lamp
C61117	Color CYC for Golden Color 1200
C52175	Truss G clamps
183102/801	Clamp fixing bracket